



PIGGY BACK[®] Delivery System

**EASY HITCH[™] Truck/Trailer
3-Position Mounting Installation
Instruction Manual**



PIGGY BACK® Delivery System

EASY HITCH™ Truck/Trailer 3-Position Mounting Installation Instruction Manual

Manual Part No.: 625-253
Rev. 1/2004

Notice: The information in this manual was in effect at the time of printing. Princeton Delivery Systems reserves the right to make improvements and changes in specifications or design, without notice and without incurring obligation. Please check with your Princeton dealer for possible updates or revisions.

**955 West Walnut Street
Canal Winchester, OH 43110
(614) 834-5000
FAX: (614) 834-5001**



IMPORTANT INFORMATION

The attached information provides suggested methods of mounting a Princeton PIGGY BACK® Delivery System to a truck or trailer.

The truck manufacturer, truck body manufacturer, and/or the trailer manufacturer should be contacted for information concerning load requirements and safe installation on their products.

The mounting methods described herein supersede any previous information.

This mounting assembly is covered by one or more of the following patents: 5,575,604 5,813,820 6,024,535.

While installing the Princeton PIGGY BACK® Delivery System mounting, the truck or trailer brakes must be applied and wheels must be chocked so that no movement occurs.

The complete mounting system must be installed to provide proper mounting and to retain full PIGGY BACK® Delivery System warranty.

Contact your State Highway Patrol for information concerning local load limits, width limits, and other limitations.

All welding must be done by certified welders with qualification in accordance with AWS D1.1.

Disconnect battery cables on the PIGGY BACK® Material Handler and the truck/trailer before welding or battery explosion may occur.

Contact Princeton for information concerning any special applications that are outside the scope of this procedure.

Contact Princeton if you have any questions about the mounting or operation of the PIGGY BACK® Delivery System.

LIMITED WARRANTY

PRINCETON DELIVERY SYSTEMS WARRANTS THAT FOR INITIAL USE THIS VEHICLE IS FREE FROM DEFECTS IN MATERIAL OR WORKMANSHIP. IF THIS VEHICLE IS DEFECTIVE UPON INITIAL USE, CONTACT YOUR AUTHORIZED PRINCETON DEALER FROM WHOM IT WAS PURCHASED AND THE VEHICLE WILL BE REPAIRED OR EXCHANGED FOR A NEW ONE. THIS WARRANTY EXCLUDES DEFECTS OR DAMAGE DUE TO MISUSE OR NEGLIGENCE.

THIS LIMITED WARRANTY GIVES YOU SPECIFIC LEGAL RIGHTS AND YOU MAY ALSO HAVE OTHER RIGHTS THAT VARY FROM STATE TO STATE. THE FOREGOING WARRANTY IS IN LIEU OF ALL OTHER WARRANTIES, EXPRESS OR IMPLIED, INCLUDING BUT NOT LIMITED TO THE IMPLIED WARRANTIES OF MERCHANTABILITY AND FITNESS FOR A PARTICULAR PURPOSE. **IN NO EVENT SHALL PRINCETON DELIVERY SYSTEMS BE LIABLE FOR SPECIAL, INDIRECT, INCIDENTAL OR CONSEQUENTIAL DAMAGES WHETHER CONTRACT, TORT OR NEGLIGENCE. AS WITH ALL HEAVY MACHINERY, THE USE OF THIS VEHICLE IS POTENTIALLY DANGEROUS IF THE OPERATOR DOES NOT EXERCISE PROPER OPERATOR PROCEDURES PROVIDED FOR YOU IN THE OPERATOR MANUAL AND HAVE READ AND BEEN INSTRUCTED ON THE PROPER LOADING AND UNLOADING PROCEDURE FOR THE PRINCETON PIGGY BACK®.**

Contents

1	General Information	5
2	Installation Kits	7
3	Major Component Photos	8
4	Fork Supports	9
5	Main Installation	10
6	Safety Chains	13
7	Tire Pad Installation	14
8	Truck/Trailer 7-Pin Wiring	16
9	Safety Signs	18
10	Detail Drawing	19
11	Mount Installation Check	20

1

General Information

These illustrations describe the factory-approved methods of mounting a Princeton PIGGY BACK® Delivery System to an owner's truck or trailer.

This section covers the general setup information on the PIGGY BACK® and truck or trailer.

NOTE: This information is necessarily general and is based on similar applications. Contact Princeton and fill out a Mounting Application Form to assure your specific truck or trailer application meets the requirements for installation of a Princeton PIGGY BACK® Delivery System.

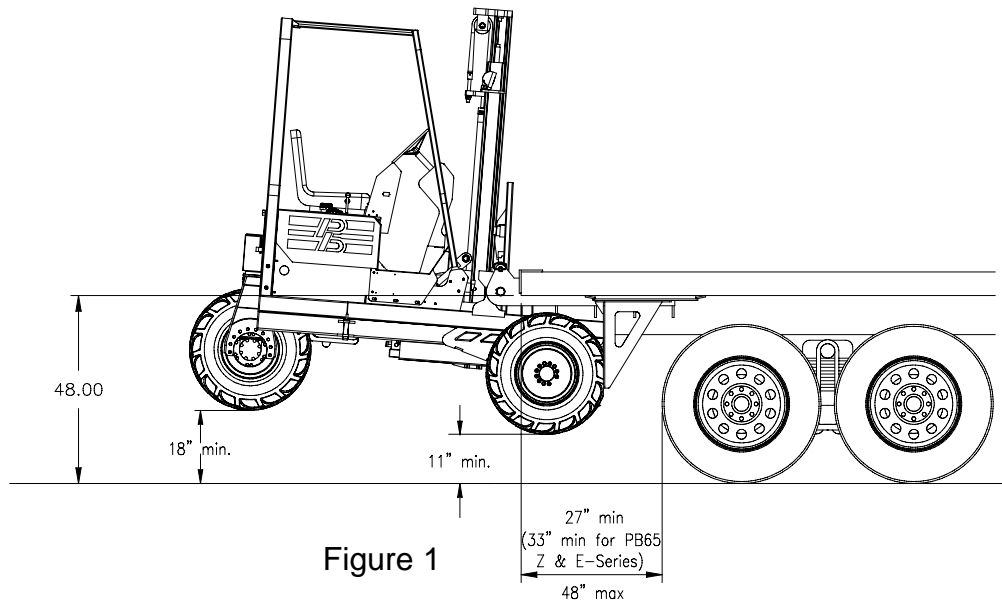

Figure 1

Dimensions

Axle Location Axles as far to rear as possible while leaving clearance for the PIGGY BACK® front tires. A minimum dimension of 27" for D45 and PB50 (33" for PB65, Z-Series and E-Series units) is recommended from the rear of the tire to the rear of the bed, with a maximum dimension of 48".

Height The PIGGY BACK® be installed as high as possible to avoid contact with the ground when driving the onto steep inclines, ramps, etc. The minimum distance from the ground to the bottom of the truck or trailer crossmember is 48". Minimum recommended distance between the front tires and the ground is 11" and between the rear tire and the ground is 18".

Structural Bed side and rear members-minimum C6 x 10.5 pounds per foot. Bed cross members-minimum C4 x 7.7 pounds per foot, 10-12" center to center.

Dimensions (cont.)

- ICC Bumper** On trailers manufactured after 1-26-98, the ICC bumper may need to be replaced with a certified bumper, similar to Sun Underride PN 103-114.
- Electrical** On most trucks or trailers, tail light buckets will need to be relocated. Tail, clearance and identification lights should be mounted as high as possible to allow the PIGGY BACK® to be raised as close to the bed bottom as possible to meet minimum ground clearance requirements. Lights should be no wider than 54" (outside edge to outside edge). Always check to insure proper light operation before and after tail light relocation.
- License Plate** The license plate bracket and light must be mounted such that they are clearly visible when the unit is and is not on the truck.
- Suspension** Air-ride suspension system is recommended.

Truck/Trailer Bed and Chassis Specifications

Standard Dimensions For Straight Truck

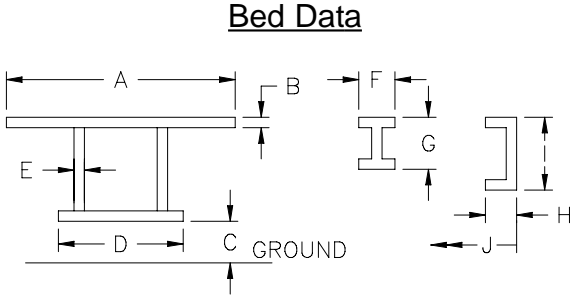
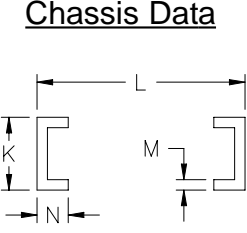
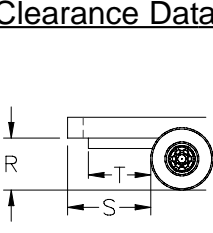
<u>Bed Data</u>		<u>Chassis Data</u>		<u>Clearance Data</u>	
					
A	92' min.-102" max.	J	20' min.		
B	5" min.	K	10" min.		
C	16" min.-22" max.	L	34" min.		
D	53" max.	M	3/8" min.		
E	3" min.	N	3" min.		
F	2" min.	R	48" min.		
G	4" min.-6" max.	S	27" min. (D45 & PB50)		
H	2.25" min.		33" min. (PB65, Z & E Series)		
I	6" min.-8" max.	T	FLUSH AT REAR		

THE INFORMATION CONTAINED HEREIN IS PROPRIETARY TO PRINCETON DELIVERY SYSTEMS OR ONE OF ITS CUSTOMERS AND SHALL NOT BE USED, DUPLICATED OR FURTHER DISSEMINATED FOR ANY PURPOSE OTHER THAN THAT FOR WHICH IT IS FURNISHED WITHOUT THE WRITTEN CONSENT OF PRINCETON DELIVERY SYSTEMS.

Dimensions (cont.)

Standard Dimensions For Trailer

Bed Data		Chassis Data	Clearance Data
A 92' min.-102" max.	G 4" min.-6" max.	M 3/8" min.	
B 6" min.-8" max.	H _____	N 4" min.	
C 16" min.-22" max.	I _____	R 48" min.	
D 53" max.	J _____	S 27" min.(D45 & PB50)	
E 3" min.	K 10" min.	33" min.(PB65, Z & E Series)	
F 2" min.	L 38" min.-44" max.	T FLUSH AT REAR	
<small>THE INFORMATION CONTAINED HEREIN IS PROPRIETARY TO PRINCETON DELIVERY SYSTEMS OR ONE OF ITS CUSTOMERS AND SHALL NOT BE USED, DUPLICATED OR FURTHER DISSEMINATED FOR ANY PURPOSE OTHER THAN THAT FOR WHICH IT IS FURNISHED WITHOUT THE WRITTEN CONSENT OF PRINCETON DELIVERY SYSTEMS.</small>			

2

Installation Kit

A complete mounting kit as described below is available from Princeton Delivery Systems.

P90.1070 Easy Hitch, 3 Position, Mounting Kit

Parts List	Item	Description	Quantity
	P80.07B	Kit, 7 Pin Trailer Receptacle	1
	P90.321A	Tubing, Mount Kit	2
	P10.376C	Chain Loop	2
	P90.291B	Chain Assembly	2
	P90.1073	Kit, Front Tire Pad Mtg.	1
	P90.1067C	Weldment, Hanger Plate	2
	P90.292A	Gusset, Hanger Plate	6
	P90.269B	Gusset	8
	P90.1069B	Bed Strengthenner	2
	P90.303B	Shaft, Hook Mtg.	2
	118-115	Snap Ring, 2" Dia.	4
	402-108	Hitch Pin	2
	604-190	Decal, Patent in Process	3
	604-127	Decal, PIGGY BACK® Transport	1
	604-143	Safety Sign Warning	1
	604-152	Safety Sign, Warning Mounting	1
	604-125	Safety Sign, Pinch Point	4
	Optional items that can be purchased		
	103-114	Sun Underride Protection Asm.	1
	P10.970B	Hook Right (Weld To Older, D5000 & Dump Units)	1
	P10.969B	Hook Left (Weld To Older, D5000 & Dump Units)	1

3

Major Component Photos



Safety Chain P/N P90.291B (2)



Retaining Ring P/N 118-115 (4)



Hitch Pin P/N 402-108 (2)



Weldment, Hanger Plate P/N P90.1067C (2)



Shaft P/N P90.303B (2)



Chain Loop P/N P90.376C (2)



Tire Pad Kit P/N P90.1073 (1)



Gusset P/N P90.269B (8)



Wire Harness P/N P80.07B (1)



Bed Strengthenener P/N P90.1069B (2)

4 Fork Supports

EASY HITCH™

Only one method of fork supports is approved with the Easy Hitch™ mounting system. The Transverse Mount uses two 2" x 4" rectangular tubes parallel to the truck axle. This method can be used on PIGGY BACK® Delivery Systems with block forks or pallet forks.

Material Required	Quantity	Description	Part No.
	2	Steel Rectangular Tubing 2" x 4" x 1/4" wall x 48" long ASTM A-500, Gr. B	P90.321A

Installation

The 48" tubing can be cut down to fit between the truck rails. However, it must be long enough to support all of the forks.

If the forks on the PIGGY BACK® Delivery Systems are 36" or longer, space the tubes at a 30" centerline with the bottom of the front tube level with the top of the rear tube. The distance between the bottom of the rear truck or trailer sill and the top of the rear transverse tube should be 3" min. Make sure both tubes are square and weld the tubing to the frame rails.

NOTE:
The bottom of (front transverse tube) must be in the same plane or lower than the top of (rear transverse tube). IF the bottom of **B** is higher than the top of **A**, the PIGGY BACK® will not have enough tilt to angle the front tires away from the tire pads when mounting and the PIGGY BACK's mounting hooks will NOT reach the mounting pins.

IF the PIGGY BACK's hooks will not reach the mounting pins, check the Tire Pad's location.

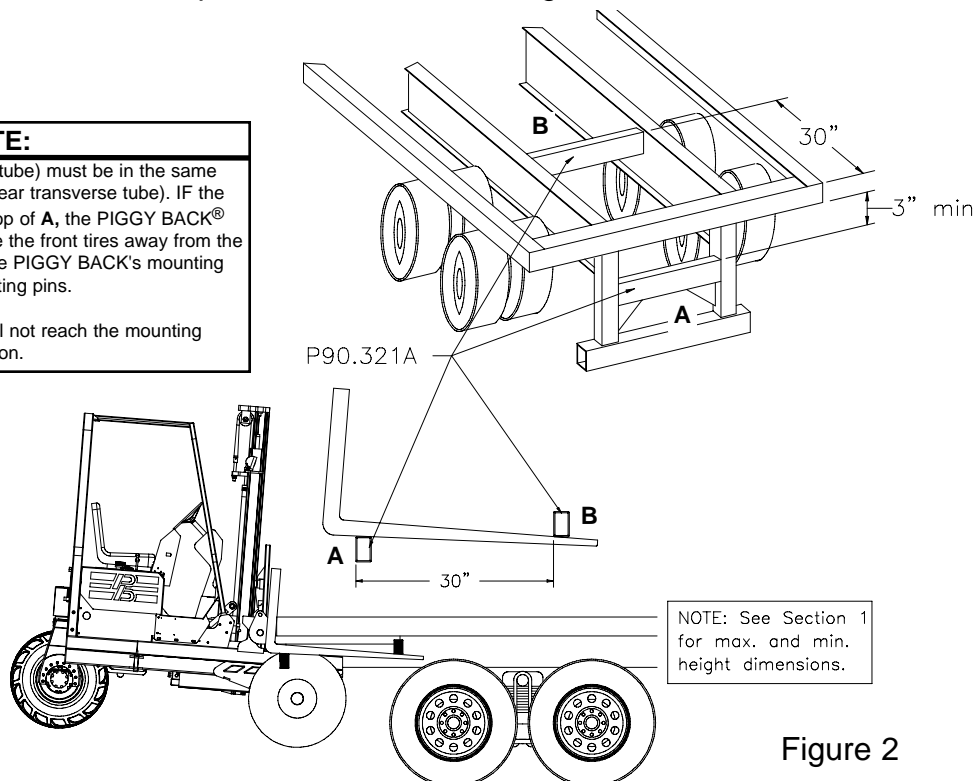

NOTE: See Section 1 for max. and min. height dimensions.

Figure 2

5

Main Installation

Hanger Plate Installation Procedure

Cut notches in c-channel at rear of bed as shown in Figure 3.
Clean weld area.

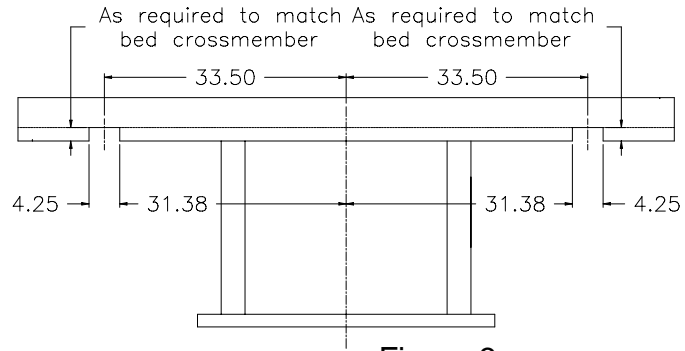

Figure 3

Measure centerlines of the truck or trailer bed crossmembers.
Install P90.292A (1/2 " x 3" x 3") Plates in the P90.1067C Hanger
Plate Weldments at each crossmember dimensional centerline as
shown in Figure 4 and Figure 5. Tack weld in place.

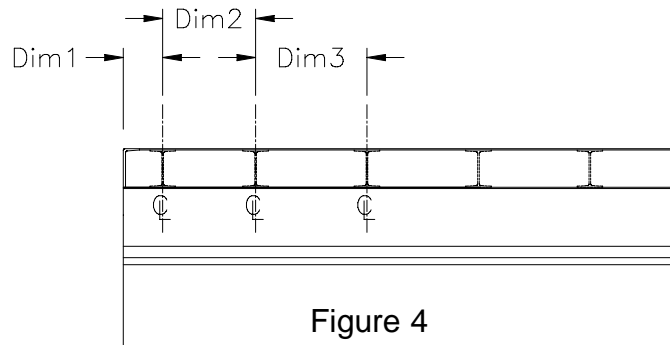

Figure 4

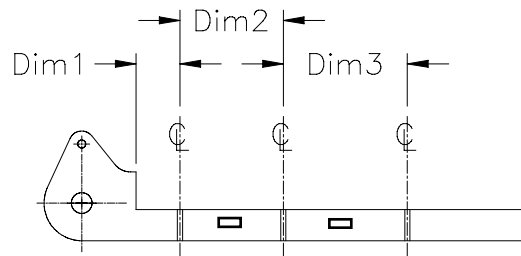

Figure 5

5

Main Installation (Cont.)

Hanger Plate Installation Procedure

Install Hanger Plate Assemblies (P90.1067C with P90.292A Gussets) at 67" centerlines as shown in Figure 6 and Figure 7. Square the assemblies and clamp them in place.

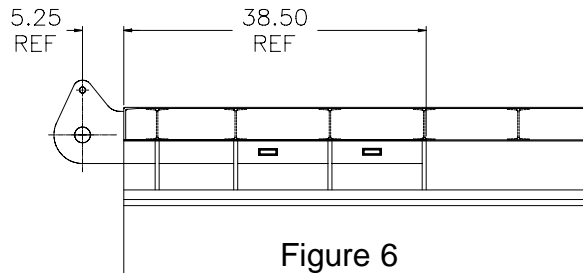

Figure 6

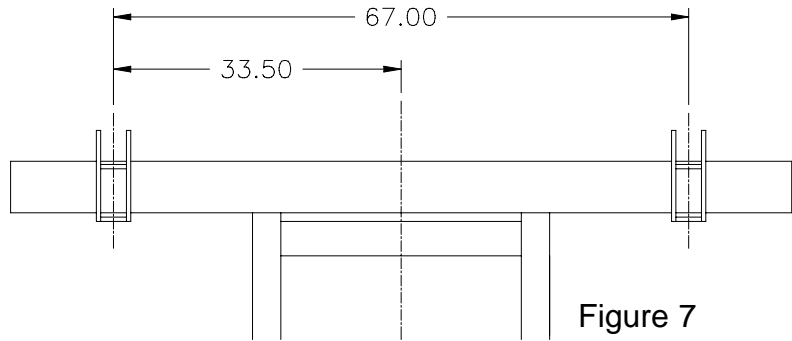

Figure 7

Install the gussets connecting the Hanger Plate Assemblies and the main c-channel as shown in Figure 8, and tack weld into place. If gussets are too long, trim to fit. Do not move Cradle Plate Assemblies.

Check to insure the Hanger Plate Assemblies are still square and at 67" centerline.

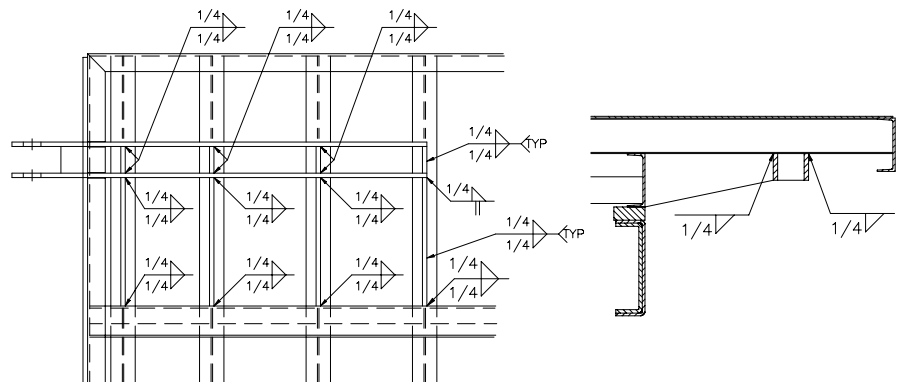

Figure 8

5

Main Installation (Cont.)

Hanger Plate Installation Procedure

Weld Hanger Plate Assembly to the rear c-channel as shown.

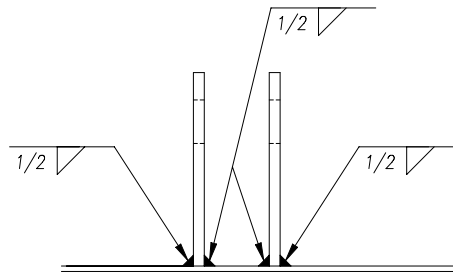

Figure 9

Prepare the Bed Strengtheners for installation as shown in Figure 10 (right shown, left opposite). Chamfer the notch to allow the Bed Strengtheners to fit over the Cradle Plate Assemblies. Also, chamfer the strengtheners to allow them to be welded together.

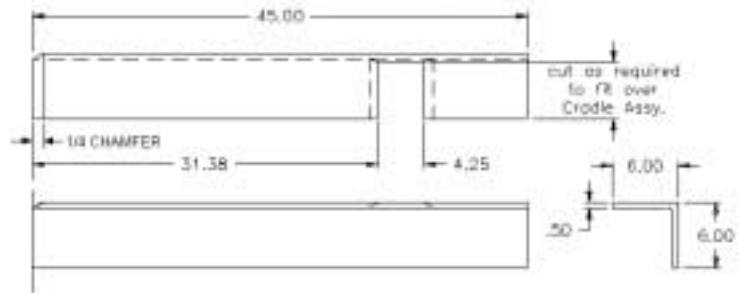

Figure 10

Locate Bed Strengthener, clean notches, and tack weld into place.

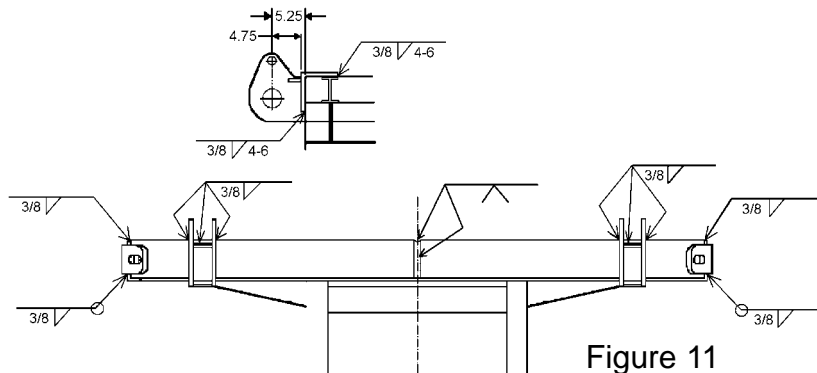

Figure 11

Complete finish welding as shown in Figure 9 and Figure 11.

Install Shafts with Snap Rings in each Hanger Plate Assembly.

Install Hitch Pins.

6

Safety Chains

The safety chains are designed to provide a compact, easy to use method of securing the PIGGY BACK® Delivery System.

Material Required	Quantity	Description	Part No.
	2	Chain Assembly	P90.291B
	2	Chain Loop	P10.376C
One P90.291B consists of the following:			
	1	Chain 1/2" high test Gr. 43 working load rating 9,200 lb.	606-108
	1	5/8" shackle w/ bolt and nut working load rating 10,000 lb.	606-106
	1	7/16" clevis slip hook w/ latch working load rating 7,200 lb.	606-107

NOTE: Standard chains may NOT be substituted.

Installation Procedure

Position the chain loops on the truck/trailer as shown in Figure 12.

Weld the chain loops securely to the truck/trailer.

Ensure that the Swing Latch Hook reaches the Mounting Bolt when the PIGGY BACK® Delivery System is mounted.

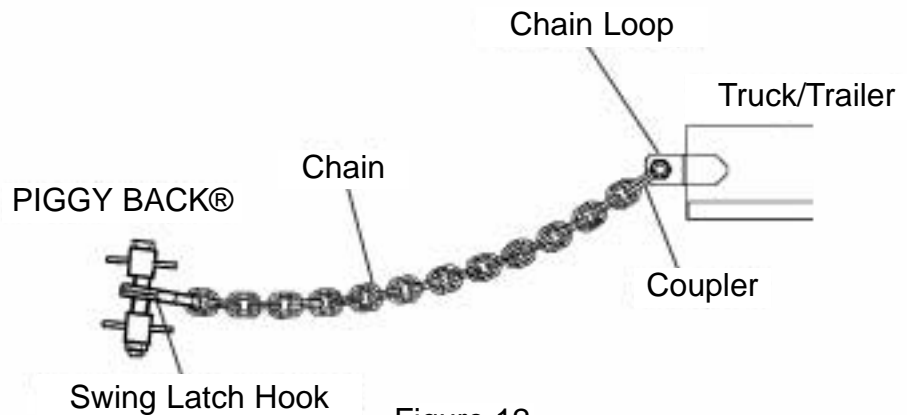

Figure 12

7

Front Tire Pads

Front Tire Pads as shown in Figure 14 reduce the loading on the mast structure and bearings. The pads should be installed so that they contact evenly and on the centerline of the tires.

Material Required Part No. P90.1073 Kit contains the following:

<u>Quantity</u>	<u>Description</u>	<u>Part No.</u>
2	Upper Base Plate	P90.1107B
1	Tire Pad Weldment, Left	P90.971C
1	Tire Pad Weldment, Right	P90.976C
8	Bolt, 3/4"-10 x 2" Long, Grade 8	8301210160
8	Lockwasher, 3/4"	8111200000
6	Gusset Plate	P90.1074B

For Standard Models

The horizontal distance from the center of the Cradle Plate Shaft to the Tire Pad is 26 1/4" thru 33 1/2" (See Fig. 14). The vertical distance from the center of the Cradle Plate Shaft to the Ground should be 48 5/8" minimum.

IMPORTANT NOTE:

If the PIGGY BACK® has front tires other than 31" diameter, fork positioner attachment, or was produced for Home Depot, these dimensions may not be correct. Contact Princeton for information on these applications.

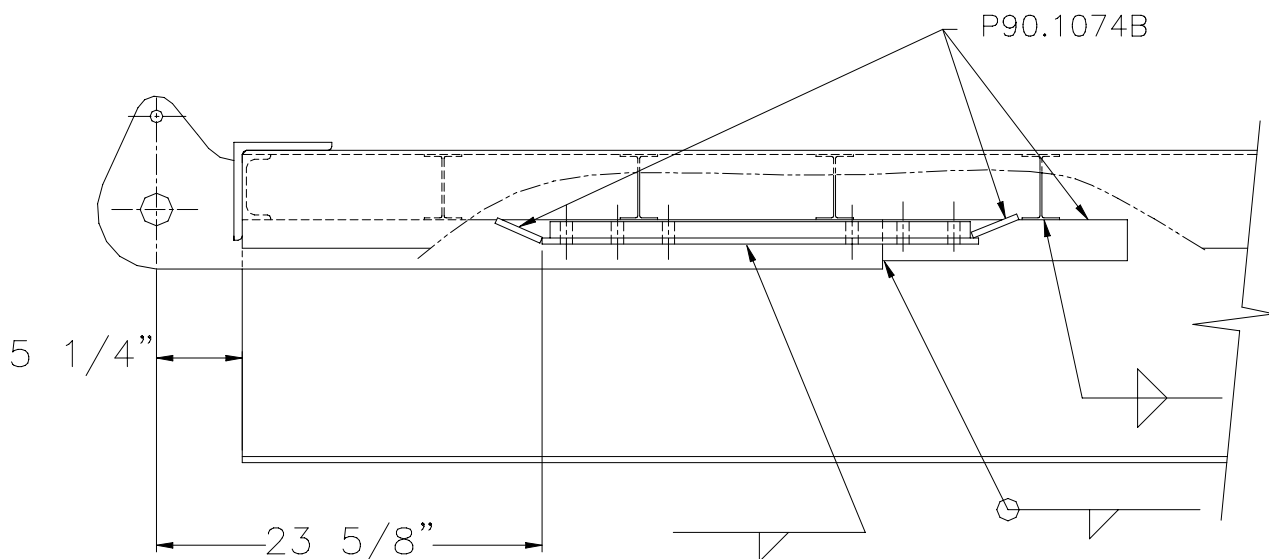

C.J.P. 8/18/03 147 AM EZ_Hitch3_PosBasePlate.dwg

7

Front Tire Pads (Cont.)

Installation

Install the Upper Base Plates (P90.1107B) by inserting the one inch tabs into the Hanger Plate Weldment slots. Clamp and tack weld the Base Plates in position. To support the front edge of Base Plate P90.1107B, use a Gusset Plate (P90.1074B). Weld one Gusset Plate to the end of the Hanger plate as shown in Figure 13 to provide a surface to continue the weld on the edge of the Base Plate. Also tack weld a Gusset Plate (P90.1074B) between the Hanger Plate and the truck bed side member. Clamp and tack weld a Base Plate to rear edge of base plate as shown in Figure 13. When setting Gusset Plates front and rear, set the plates at an angle to Base Plate for increased strength .

Install Tire Pad Weldments with 3/4"-10 x 2" Lg. Grade 8 Bolts and lockwashers. Refer to Figure 14 for proper location of Tire Pad Weldments. If a PIGGY BACK® is available, check tire pad placement by mounting the unit. Remove Tire Pads and finish welding Base Plates.

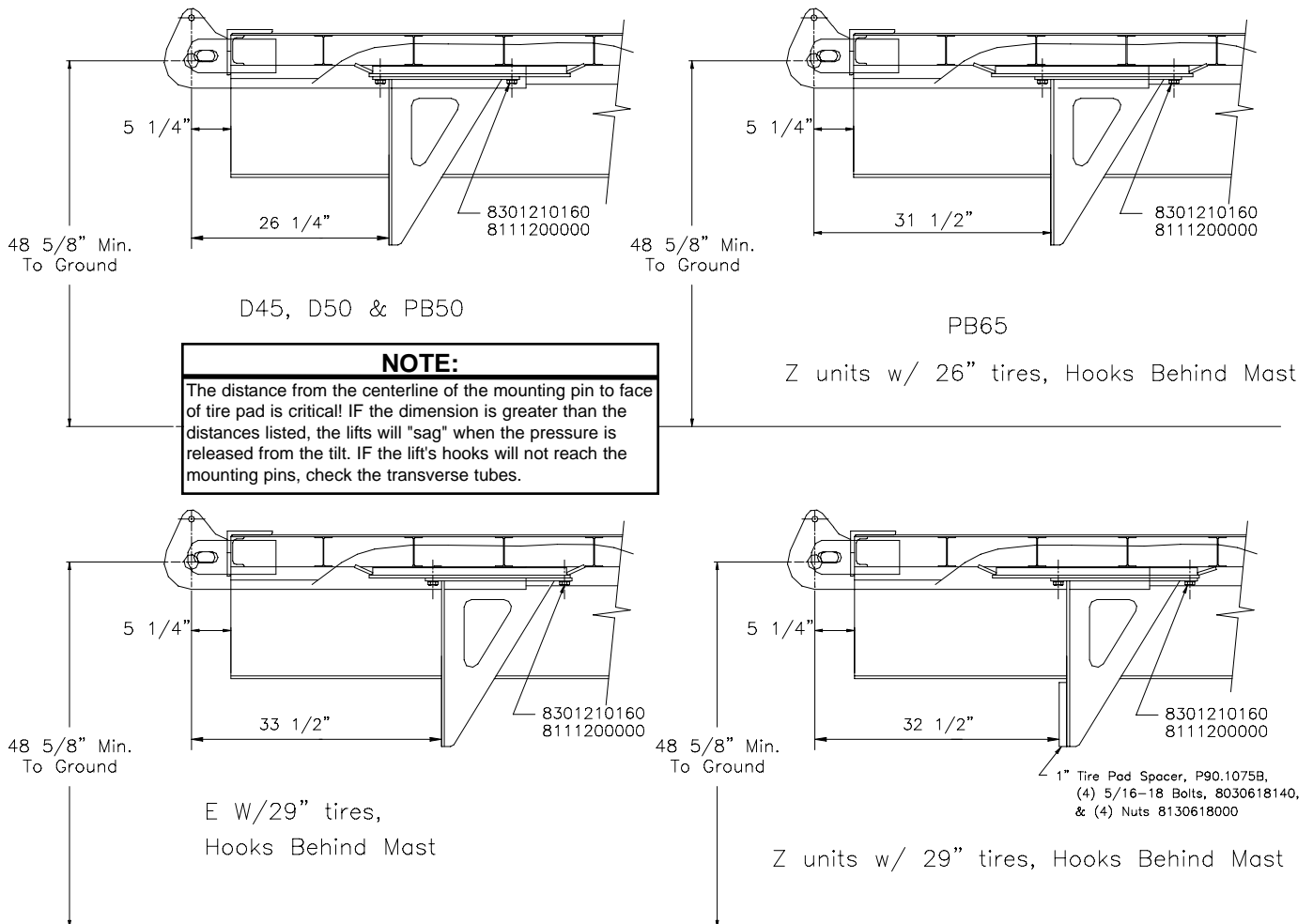

Figure 14

8

Truck/Trailer 7-Pin Wiring Kit

Material Required	<u>Quantity</u>	<u>Description</u>	<u>Part No.</u>
	1	Truck/Trailer Receptacle Kit	P80.07B

Installation

To determine the location of the receptacle, mount the PIGGY BACK® to the truck/trailer. Since the PIGGY BACK® receptacle is located in its left side, locate receptacle to the left side of the truck/trailer. The coil plug provided with the PIGGY BACK® is approximately 12 feet long at full extension for mounting location flexibility.

With the unit mounted, insert the coil plug into the receptacle on the left side.

Stretch the cable to the truck/trailer to determine a convenient and protected location for the truck/trailer receptacle.

With the receptacle location determined, lay out the mounting holes.

Drill or torch out a 2" diameter through hole for the receptacle body.

Feed the receptacle harness through the hole and mark the location of the mounting holes. Drill 2 holes, 3/16" diameter for self-tapping mounting screws. Secure the receptacle to the truck/trailer with the screws.

Wiring - Trailer

With the seven tap-in connectors provided, splice into the trailer wiring. In the package, there will be six blue and one yellow wire taps. The yellow tap is for the white wire or ground.

All wiring is required to be color coded to S.A.E. Standards. Use Table 1 to locate the proper wire for trailers that have separate turn lamps & stop lamps.

If you have taken the unit off the trailer, reload to check electrical installation. Install coil plug from your trailer to the receptacle on the left side of the forklift. The plug can go in only one way to ensure proper alignment of wires.

Wiring - Truck

With the seven tap-in connectors provided, splice into the truck wiring. In the package, there will be six blue and one yellow wire taps. The yellow tap is for the white wire or the ground.

All wiring is required to be color coded to S.A.E. Standards. Use Table 2 in to locate the proper wire for trucks which have combined turn lamps & stop lamps.

To use both lights on each side of the PIGGY BACK®, cut the red wires to the outside lamps and at the connector. On the left pair, install a jumper wire to connect to the yellow wire on the inside lamp to the red wire on the outside lamp. On the right pair, install a jumper wire to connect to the green wire on the inside lamp to the red wire on the outside lamp.

8

Truck/Trailer 7-Pin Wiring Kit (cont.)

If you have taken the unit off the truck/trailer, reload to check electrical installation. Install coil plug from your truck/trailer to the receptacle on the left side of the forklift. The plug can go in only one way to insure proper alignment of the wires (Figure 15).

Table 1 - Wiring Circuits - Trailer with Separate Stop and Turn Lamps

<u>Conductor</u>	<u>Wire Color</u>	<u>Lamp and Signal Circuits</u>
Wht	White	Ground return to towing vehicle
Blk	Black	Clearance, side marker, and identification lamps
Yel	Yellow	Left-hand turn signal and hazard signal
Red	Red	Stop lamps and anti wheel lock devices
Grn	Green	Right-hand turn signal and hazard signal
Brn	Brown	Tail and license plate lamps
Blu	Blue	Back-up lamps

Table 2 - Wiring Circuits - Truck with Single Stop and Turn Lamps

<u>Conductor</u>	<u>Wire Color</u>	<u>Lamp and Signal Circuits</u>
Wht	White	Ground return to towing vehicle
Blk	Black	Clearance, side marker, and identification lamps
Yel	Yellow	Left-hand turn signal, hazard signal, and stop lamp.
Red	-	Not Used.
Grn	Green	Right-hand turn signal, hazard signal, and stop lamp.
Brn	Brown	Tail and license plate lamps
Blu	Blue	Back-up lamps

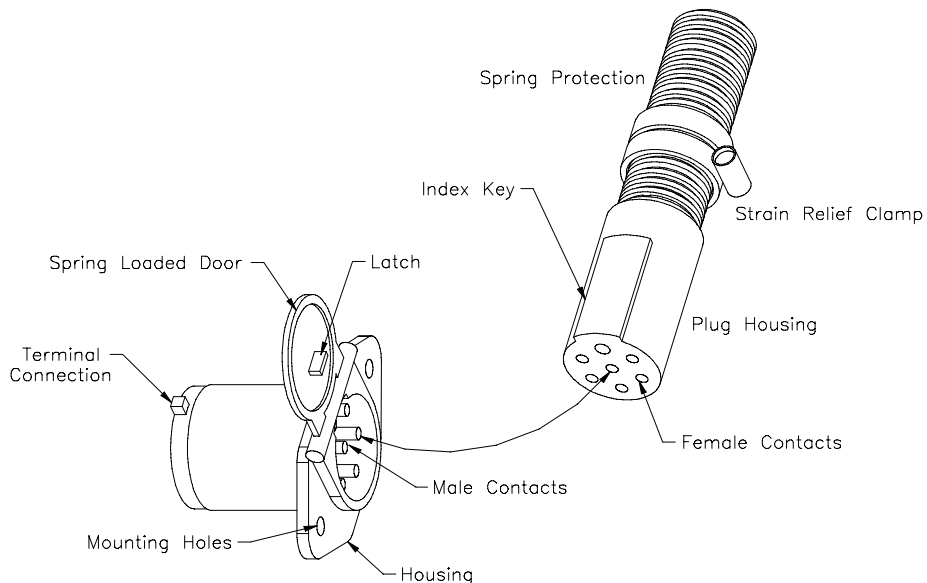
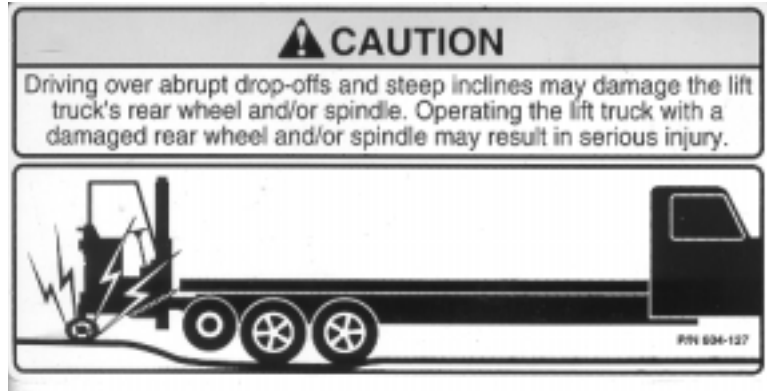

Figure 15

9

Safety Signs Install safety sign 604-127 (shown below) on the truck dashboard or other prominent area.



Install safety signs 604-143 and 604-152 (shown below) at the rear of the truck/trailer.



Install safety signs 604-125 (shown below) on the Cradle Plates & Tire Pads of the truck/trailer.



10

Detail Drawing

Component Identification (Contact Princeton if additional drawings are needed.)

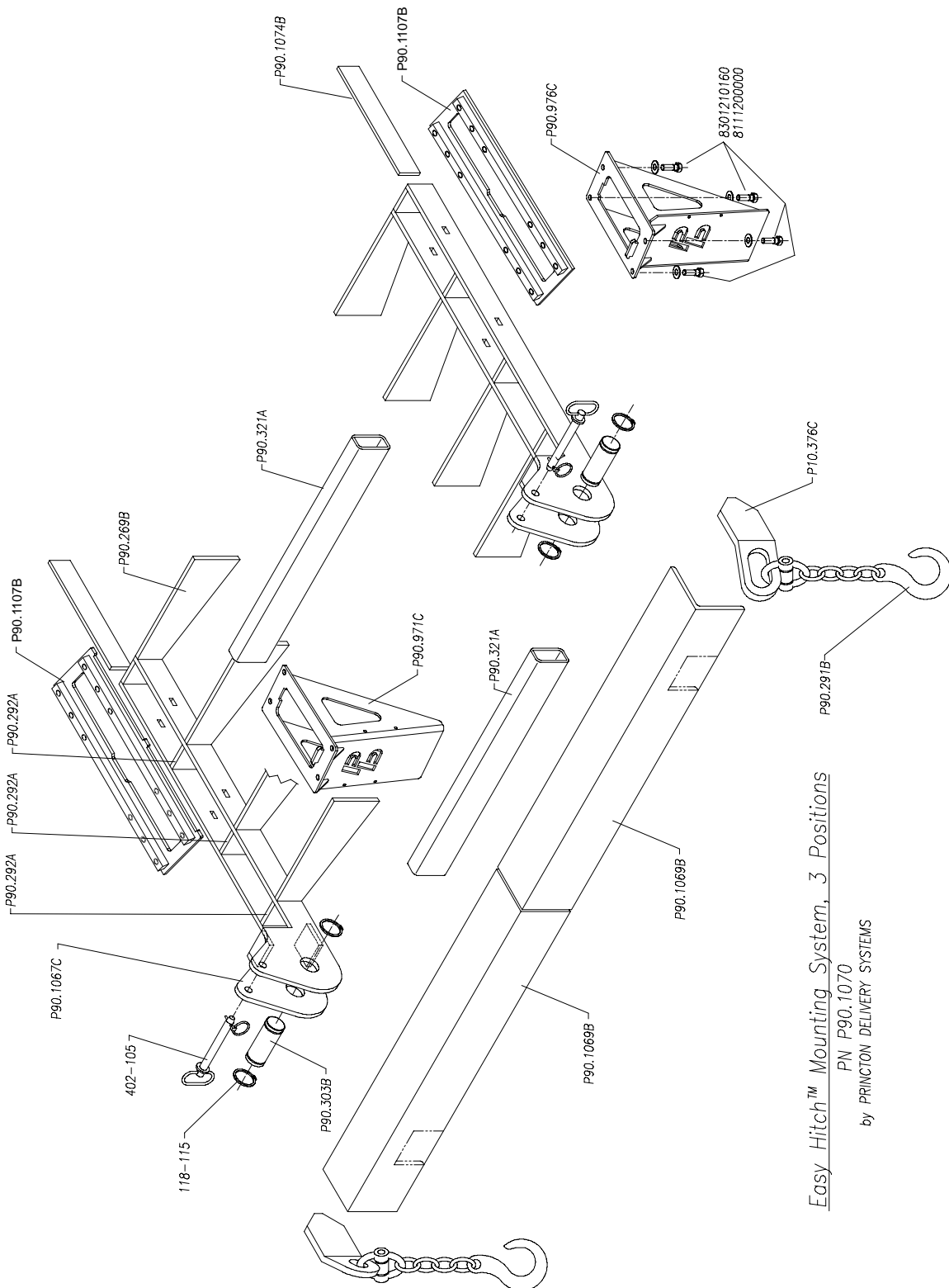

Easy Hitch™ Mounting System, 3 Positions

PN P90.1070

by PRINCETON DELIVERY SYSTEMS

11 Mount Installation Check

Mount the unit per 625-244 and check all points of installation including fit and function.

Make sure 7-pin connector mates and safety chains are the right lengths.

The PIGGY BACK® Delivery System may be equipped with an Automatic Tilt Release. Check for proper operation at this time. Leave the PIGGY BACK® away from the Tire Pads. Depress the brake pedal on the truck or activate hazard lights on the trailer and look for PIGGY BACK® movement.

Installation is now complete.

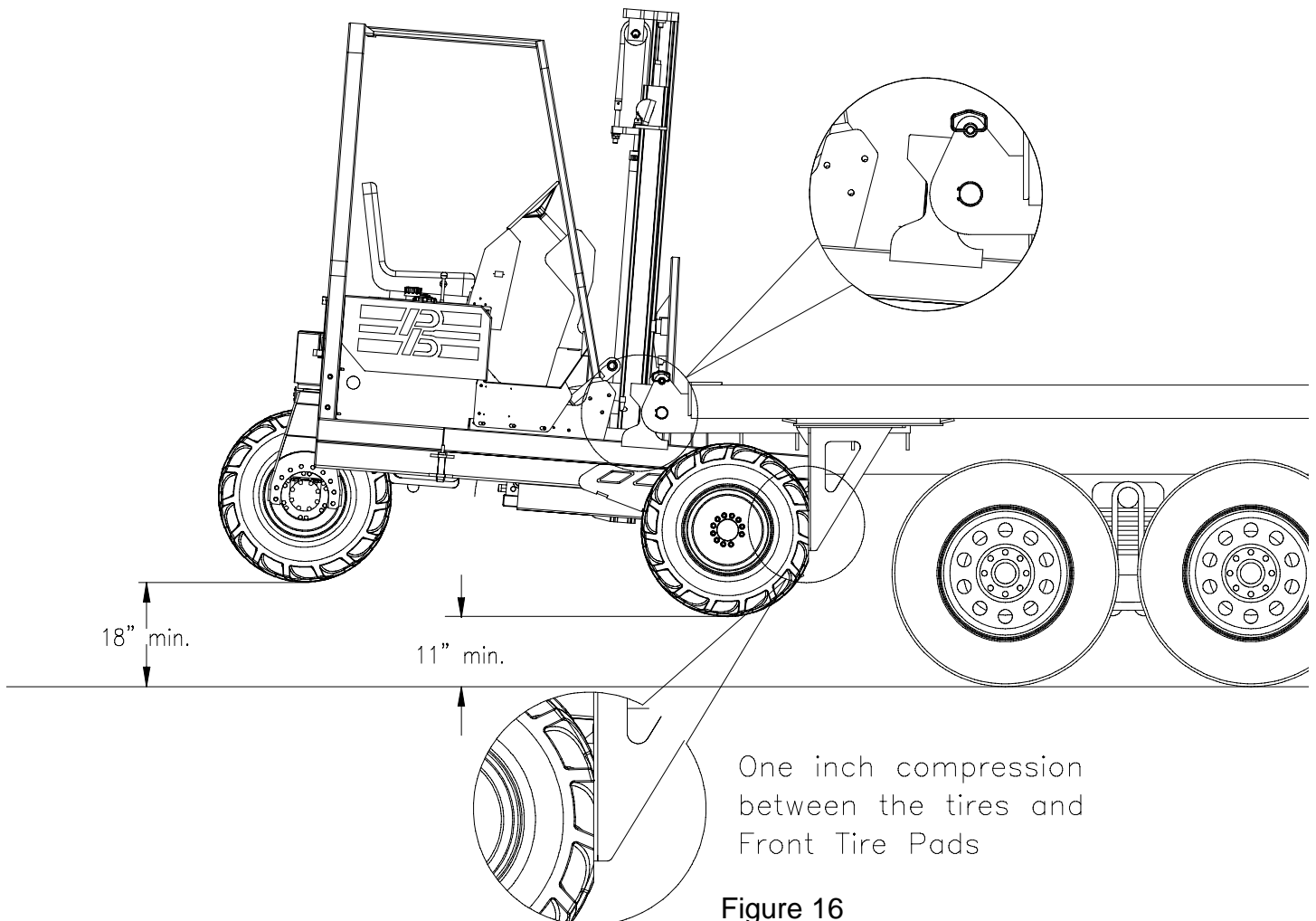

Figure 16